

Cruisin' at the speed of fun

Mass Cruisers Auto Club

August 2024



ALSO INSIDE:

BOARD OF DIRECTORS MUSINGS *Page 3*

WEEKLY CRUISING CALENDAR *Page 11*

CAR SHOWS, EVENTS & SWAP MEETS *Page 12*

Let's Go CAMPING



Celebrating 33 Years of Cruisin'
Volume 33 Issue 8

We're on the Web

www.masscruisers.com

Facebook and Instagram



Contact us by snail mail:
P.O. Box 217, Wrentham, MA 02093
Or by email: HO350@comcast.net

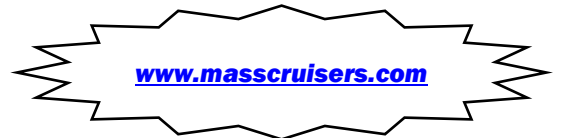

2024 Monthly Business meetings are usually held in the Bass Pro Shops Conservation Room on the third Tuesday of the month at 6:30 PM. Visitors, guests and those interested in joining the Mass Cruisers Auto Club are welcome to attend one of these monthly meetings at 6:30 PM before club business is conducted.

DIRECTORY	Page 2
BOARD MUSINGS	Page 3
EDITOR MUSING	Page 3
FACTORY FIVE MK-4	Page 4
1952 FORD RANCH WAGON	Page 5
1928 MAXIM FIRE ENGINE	Page 6
NEW BEDFORD 50'S NIGHT	Page 7
WENTWORTH CAR SHOW	Page 8
TOOLS-4-KIDS	Page 9
SEMA ACTION NETWORK	Page 9
SUPPORT OUR SPONSORS	Page 10
CRUIZN MASSACHUSETTS	Page 11
APRIL/MAY EVENTS PAGE	Page 12

2024 Board Members

Rich Armando (CHAIR)
Bob Hines
Steve Huntington
John Griffin
Diane Thornton
John Sturniolo
Kevin Rushlow
Secretary: Open
Treasurer: Kevin Rushlow
Asst. Treasurer: Rich Armando
Board Emiratis: John Buchanan
Larry Nyborn
Webmaster: Dennis DiBiasio
Asst: John Griffin
Managing Editor: John Buchanan
Facebook: Steve Vining
FB Admin: John Buchanan
FB Admin: Sean Sullivan
New Members: Lou Valentine
Sgts. at Arms: John Sturniolo
Charity Coordinator: Rick White
Joe Renaud
Food Pantry: John Griffin
Steve Fernald
Dennis DiBiasio
Mark Magno

Our Major Cruise Sponsors

POPE
INSURANCE AGENCY
A WORLD COMPANY
Antique, Classic, Custom,
Muscle Car Specialists
27 Elm Street North Attleboro, MA 02761
(508) 695-7938 www.Popelns.com

2nd Generation Stan C.
Automotive Restorations
Specializing in Muscle Cars & Corvettes
2000 Main Street Unit 17 - Walpole, Ma 02081
Ph. 508.641.5442 Fax 508.660.1271

ZEKE'S CUSTOM AUTO, INC.
1988 WINTHROP ST. • ROUTE 44 • N. DIGHTON • MA 02764
Large Selection of
MICHAEL THIBODEAU
Tel. (508) 252-4312 • (508) 252-5358
Fax (508) 252-4008
E-Mail: Sales@zkesonline.com
www.zkesonline.com
www.zkescustomwheels.com
• Custom Wheels • Tires
• Custom Auto Parts
• 4 x 4 Accessories
• Lift Kits

HAGERTY
FOR PEOPLE WHO LOVE CARS™
MICHAEL SAKKAS
TERRITORY MANAGER BOSTON, MASSACHUSETTS
mobile: +1.774.205.0958
msakkas@hagerty.com

IMMORTALIZE YOUR CAR
Professional cinematic video of your car.
Video packages from \$499 to \$2499
(800) 710-1642
sales@overlandfilmworks.com
OVERLAND
FILMWORKS

FACTORY FIVE
RACING
Contact Us
508-291-3443
info@factoryfive.com
9 Tow Road
Wareham, MA 02571
www.factoryfive.com

Our Major Cruise Sponsors

SECURE CAR STORAGE
YOU KEEP YOUR KEYS
WINTER STORAGE
- Flexible Duration
- New Facility
Call for more information
646-623-9357 / 617-320-7419
Email: info@abesgarage.com

Kubota **TEREX**
Norfolk POWER EQUIPMENT
SALES, SERVICE, PARTS & RENTALS
5 Cushing Dr. Rte. 1A
Wrentham, MA 02093
tel: (508) 384-0011
fax: (508) 384-8667
info@norfolkpower.com
846 Bronco Hwy
Burrillville, RI 02830
tel: (401) 710-9911
fax: (401) 710-9466
www.norfolkpower.com

DENNIS FOLAN **COLDWELL BANKER** LIFESTYLES
Cell: (508) 801-6444
Office: (781) 320-0550
692 High Street
Westwood, MA 02090
www.DennisFolan.com
www.Dennis.Folan@NEMoves.com
I can find that unique home for auto enthusiasts

Greg Pellegrino
Owner
Shop: 508-429-4241
Cell: 508-250-4355
Vintage Motorsports
vintagemotorsportsgarage.com
86 Washington Street • Holliston, Massachusetts 01746

By-Laws: Wayne Lestan
MAAC Rep: John Buchanan
MAAC Alt.: Glenn Brayman
Cruise Director: Bob Hines
Asst. Director: Rich Armando
Cruise Trailer: Lorna Rabbitt
Diane Thornton
Marie Armando
Jean Waite
Sponsors: John Buchanan
Fred Tierney
Club Events: Rich Armando
Photographers: Steve Vining
Sean Sullivan

TAKE A
Kid Car
TO A Show
ARMO
AFFORDABLE RESTORATION
MARKET ORGANIZATION
www.TakeAKidToACarShow.com



Board Musings

By Rich Armando



Even with morning rain, heat and humidity at our last cruise on July 11, it turned out to be O.K.. Although the turnout was lighter than we normally experience it was still a good turnout, some 600–700 cars. It was also good to see Michael and Lorna Rabbitt's daughter Jeanette at the cruise night. She was up from Kentucky visiting for a few days and what better way to spend some time with her parents than to come to our cruise night. Now that's dedication from the whole family. Jeanette was asked to join her parents in selecting two favorite cruise cars to receive their Vintage Motorsports sponsored cruise winner awards.

Our charity of the night was the AMVETS Post 51 of Randolph. As always you can depend on veterans to get the job done. Our contact Lou could not attend to help as he just had surgery to repair a broken hip he had suffered. The word was put out that there better be a lot of veterans in attendance to help with the 50-50. Around a dozen Vets showed up to lend a hand and the results were excellent. With a lower than normal turnout they were able to collect \$864 which is a good amount as our food pantry donations usually cut into what 50/50 proceeds we collect for the charity of the night. What made this even more special was, instead of splitting the 50/50 to the AMVETS and the winner, the winning ticket holder gave back all to the veterans. I don't know who the winner was, but thank you for your generosity. I've been told what makes this a special night for the AMVETS is that all of the proceeds go directly to the Veteran residents at the VA hospital in Brockton. They are treated with events like an ice cream social or other onsite events they attend to try and give these patients a few hours of enjoyment. None of this goes into a general fund where it can be spent on red tape or bureaucracy. A job well done.

A few days ago I was notified by Patriot Place that our August 22nd cruise night will have to be rescheduled due to an extremely busy week for the stadium. It seems like there are events going on August 21, 23, 24, and 25 so staffing would not be available on the 22nd. Patriot Place has offered us August 29th, one week later as a makeup date which we have agreed to. I hope you can rearrange your schedule to attend this cruise night.

Once again, everyone attending the Downtown New Bedford '50's cruise night, as in the past, was a very enjoyable evening. There were plenty of cars to look at, 5 live bands and several DJ's "spinning" your favorite tunes throughout the Union Street area and, to top it all off, the weather was near perfect. A few members had car issues, but that can sometime happen. It was great to see fellow club members stick around to lend a hand to try and correct the problems. Unfortunately it was something that could not be fixed that night so a ramp truck was called. What happened is exactly what I tell members who do not want to drive their cars far for fear of a break down. When you attend a car event with members and anyone has an issue with their cars, you will not be left alone. When you see fellow member Al Provost, thank him for taking the time to set up cones to secure an area reserved for the Mass Cruisers. Thank you Al.

Editor's Musing

By John Buchanan EDITORIAL



BUMMER! Our July 25 Bass Pro Shops cruise was rained out, the third so far in 2024. To top it off, we won't be hosting a Thursday Bass Pro Shops cruise at Patriot Place until August 29. And that date was a last minute reschedule change because the original scheduled August 22 cruise date could not be supported due to the resource squeeze resulting from Pink's Wednesday August 21 "Summer Carnival Tour" and the big Friday August 23 through 25 Kenny Chesney & Zac Brown Band "Sun Goes Down" Tour at Gillette Stadium. Of course, we expect at least one Thursday night Patriot Game conflict at Gillette and our scheduled August 8 cruise fell victim to that. Of our originally 2024 planned 15 cruise nights at Patriot Place, we've experienced 3 weather related cancellations 2 Gillette event cancellations and one reschedule date through the first 9 cruises. We have asked Patriot Place if they have any open Thursday nights in September and October to possibly pick up another one or two nights to make up what we have lost to this point.



MAD, #63 1961 April Showers Issue



JULY 11 CRUISE WINNER FACTORY FIVE MK-4

by John Buchanan

As you walk around John Webster's Factory Five MK-4 Roadster, one of the two Vintage Motorsports cruise winners at our July 11 cruise, you notice details that are unique to this 12-month build-project unlike many of the Factory Five MK series roadsters that regularly attend our cruise. Most obvious is the splash/siphon guard surrounding the polished aluminum Shelby Cobra Style Gas Cap and its 289 kit location behind the passenger seat. Then you look over to the Petty roll bar and notice the speedo is also mounted on the passenger side along with a replica Shelby American COBRA tag. You now understand that John, not only built his first MK-4 Roadster, he made it a tribute replica of the famous 1965 era Carroll Shelby 289 Cobra's along with their added FIA optional rule features like the trunk dimples for a required 24" x 16" x 8" suitcase and drilled bungee cord holes to keep the poorly latched trunk from flying open when racing. Shelby only built 5 USRRC/FIA 289's for racing with only two know to exit today, making this MK-4 very unique. However, not wanting an older drive train for reliability and performance, John chose the venerable Boss 302 V8 that dyno's out at 355 HP & 346 Ft. Lb. torque and is backed by a Tremec T-5 tranny & mid-shift kit, Moser rear w. 3.55 gears & Koni coil overs with 3-link rear and double A arms up front. He also added heated seat kits for those cool New England morning drives to car shows. Nicely done John.



Notable features like the Petty roll bar, gas cap splash siphon guard, suitcase trunk dimples & bungee cord tie down highlight John's Factory Five MK-4 as a tribute 1965 Shelby Cobra USRRC/FIA 289.





JULY 11 CRUISE WINNER 1952 FORD RANCH WAGON

CONTINUED FROM Page 4

I don't think there were too many that missed seeing Scott Morrell wheeling into our July 11 Bass Pro Shops cruise with their Milford Auto Sales recent Barrett Jackson California Auction acquisition, a combination 1952 Ford Mainline Ranch Wagon towing its rare matching Kompac Sportsman Trailer. As a result, it was picked for one of our two Vintage Motorsports cruiser awards. The trailer has it all for the outdoorsman. It can sleep two and has a tailgate galley area that houses a 5.4 cubic foot ice refrigerator, a portable gas grille, and an 8-gallon water tank. And the most striking of all, the trailer's roof is its upside down fully functional 12-foot-long fiberglass boat, that when removed has a canvas top roof. Although missing from this package, it originally came with a 3 hp Johnson outboard motor that folded to fit into a space-saving suitcase. Because the list price for the trailer in 1952 was advertised for about the same price as Ford's first year lower cost all steel boded ranch wagon, only 15 were built. This one spent most of its life stored indoors, so it's in mint condition sporting the same Meadowbrook Green and Sungate Ivory paint as the wagon. If you have any interest in learning more about this unique vehicle, you can see it at Milford Auto Sales in Hopedale or look on the Hemmings Marketplace where more photos are posted.



This rare Kompac Sportsman matching camping trailer with its first year all steel Ford Mainline Ranch Wagon was the perfect cruise vehicle to make it to a Bass Pro Shops cruise night.





JULY 11 CRUISE WINNER 1928 MAXIM FIRE ENGINE

by John Buchanan



The Maxim Motor Company in Middleborough, MA specialized in manufacturing fire fighting equipment from its founding in 1914 by its then fire chief, Carlton Maxim, who thought he could build a better fire engine than the town had recently purchased. Since that beginning, Maxim produced over 3,000 fire engines up until it ended operations in 1989. A side note, in 2009 Maxim was re-established as a brand of custom fire apparatus by North Attleborough's Greenwood Emergency Vehicles. The nearby town of Stoughton, MA purchased a new 1928 Maxim pumper fire engine and put it into service up until 1956. During the 2020 pandemic recovery, Joe Mokrisky, President of the Stoughton Historical Society, was able to secure a grant to have Gaspar's Automotive Restoration in Manchester, CT, restore their Engine #2 over a two-year period and, having just gotten it back two months ago, Joe was able to bring it to our July 11 cruise to show it with the Rhode Island Antique Fire Apparatus Society display that Richard Quetta organizes every year.



Here's something good following the 2020 Pandemic, this 1928 Maxim Pumper restoration project thanks to the Stoughton Historical Society obtaining a Massachusetts Capital Preservation Funding grant along with Town meeting approval in 2021 and completed by Gaspar's Automotive Restoration in Connecticut followed by town unveiling in June 2024.

[Stoughton Massachusetts 1928 Maxim fire engine final reveal. \(youtube.com\)](#)





Cruisin' at the speed of fun NEW BEDFORD 50'S NIGHT

by John Buchanan

Every 3rd Thursday in July, the tradition of hosting a 1950's era cruise-in car show event in downtown New Bedford harkening back to those days when teens used to drive back and forth through their hometown streets on the big shopping night blasting out their favorite AM radio station's latest Rock & Roll tunes. Those shopping nights downtown suffered when shopping malls arrived in the 1970's. In 1990, a downtown merchant named Joe Jesus recruited other fellow business owners and the city to host an annual nostalgic cruise-in with D.J.'s and live bands. Joe died in 2019 and, with the 2020 pandemic, so did its annual 50's night, that is, until 2022 when the widow of a regular 50's night participant of the cruise, that would attract hundreds of classic cars and hot rods and thousands of spectators, stepped up and offered to fund it's revival. To be sure this event will continue into the future, several of the local car clubs are collecting a \$10 donation from the show car participants, a nominal amount when there are at least 3 D.J.'s and five live bands entertaining everyone from 6 to 9 PM. This year the cruise was expanded down the entire length of Union Street, from 6th Street to Rte. 18, experiencing the largest turnouts due to perfect weather according to Bob Bramwell, President of the Cuz's Car Club. The Mass Cruisers also enjoyed reserved parking along Union Street at Wings Court.



Club members relaxing in Wings Court while their cars are parked close by along Union Street

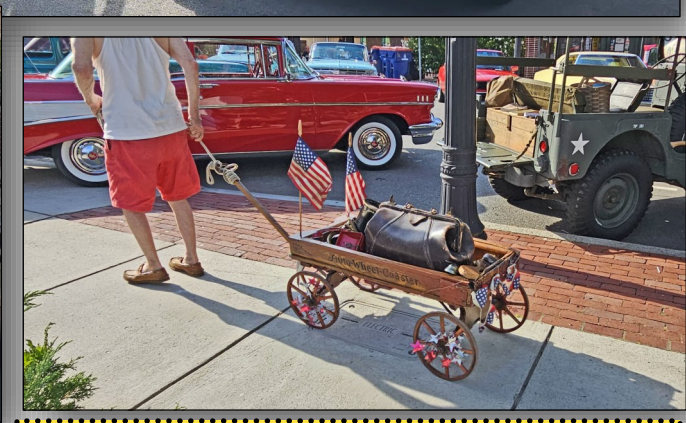

There were some dozen or so Mass Cruisers cars parked along Union Street, with Kevin Rushlow's 1975 Cadillac El Dorado (above), Rich & Marie Armando's 1968 Chevelle (above that) and Joe Renaud's 1956 custom Chevy pickup truck (above right)

You never know what will come rolling down Union Street at the annual New Bedford 50's, "Joe Jesus Tribute" cruise in car show. Above is a vintage wooden Auto Wheel Coaster wagon filled with a collection of vintage stuff.



WENTWORTH LEOPARD RACING CAR SHOW

by John Buchanan

The Wentworth Institute SAE Leopard Racing Club members conduct an annual car show at their Huntington Avenue Campus each July. Although the show isn't heavily promoted, a few of our club members, some former alumni like myself, like to attend each year to show support for the club's Baja Race Car build project. Also, Herb Connors, the Wentworth Engineering School Lab Director, likes to bring some of the SAE club members to our Bass Pro Shops spring cruise. Although there were only two of us attending this year's show, John Ricker with his Mount Washington "Climb to the Clouds" racing 1986 Porsche 944 Turbo and me with my 12 year old great grandson Brad in the '91 Mustang 7-Up edition convertible, both cars came away with trophies for Best Race Car and Best Ford.

The Society of Automotive Engineers (SAE) Baja club at Wentworth is about eight years old with over 30 active members ranging from freshmen to seniors and from mechanical engineering to construction management majors. Their members have a passion for cars, trucks, motorcycles, and the challenge of designing and building a prototype of an all-weather, rugged, single-seat, off-road recreational vehicle intended for sale to the nonprofessional weekend off-road enthusiast. They compete nationally with as many as 60 to 100 other college clubs.

The annual car show allows the SAE Leopard Racing Club to showcase their current SAE Baja Race Car design that will be competing in the September 2024 SAE Baja competition in Michigan. Here's a YouTube link of the showing the 2023 SAE Baja competition that was held in Ohio that highlights the annual event's scope and intensity among the competing teams. [Baja SAE Williamsport](#) They are also looking forward to a

newly created Formula Electric team, which is planning on being competition ready for the 2025 season. We'll look forward to seeing them again next July.



From a 3-D model chassis design to complete build, Wentworth SAE Leopard Racing Club members spend a couple of hours, two late afternoons each week, during the year getting their single seat off-road four-wheel drive ready to compete annually each year against 60-100 other college SAE Racing Clubs.

John Ricker's Mount Washington "RACE TO THE CLOUDS" prepared Porsche Turbo was a hit with the Wentworth SAE Leopard Racing Club members.

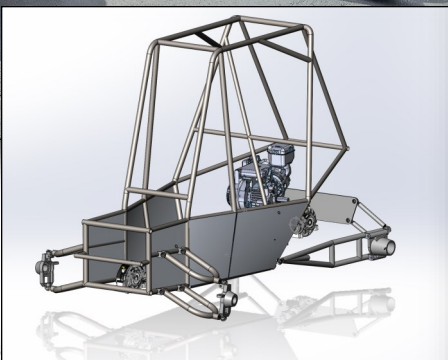

My 12 year old great grandson, Brad & John Ricker hold their trophies for Best Ford and Best Race Car.



Cruisin' at the speed of fun TOOLS 4 KIDS: SOCKET-2-ME

by Rick White



Like all of our charity efforts it's hard to collect tool donations for our TOOLS 4 KIDS program when our cruises are cancelled. Despite these setbacks we've continued our push for giving a second life to unneeded back up tools. While sorting and arranging tools into sets I've noticed no ratchet wrenches or sockets have come in this year. So, SOCKET-TO-ME. Rather than dump a bucket of sockets into the abyss of donations to our supported automotive tech students, we sort and arrange socket sets with the purchase socket rails. Brands don't matter but a complete sized set to be upgraded later is our goal. Will they remember our donations to the abyss or a usable starter set? Ratchet wrenches are few and far between. Not to mention metric . So SOCKET-TO -ME!!!!



SEMA ACTION NETWORK

by John Buchanan



The SEMA Action Network (SAN) was formed in 1997 to unite vehicle clubs and enthusiasts with members of the specialty auto parts industry as a political voice for the hobby. As the Massachusetts 193rd General Court ended its 2023–2024 formal session in July without any legislative action seen on bills beneficial nor on bills that could prove harmful to our hobby, it is also a good time to check the pulse of legislative activity across the country using the SEMA Action Network website [Home | SEMA ACTION NETWORK \(semasan.com\)](http://Home | SEMA ACTION NETWORK (semasan.com)) to learn what actions affecting the hobby in other states could possibly work their way into our own state's legislative process when the 194th General Court convenes in January 2025. California usually provides the model by which other states will soon follow.

- A warning shot across our bow occurred on October 9, 1993 when, as part of their strategies to achieve 100% zero emissions by 2035, California Gov. Gavin Newsom signed a law, AB1346, that will effectively ban the sale of gas-powered small off-road engines — spark-ignited engines rated at or below 25 hp. The bill directs the California Air Resources Board (CARB) to ban the sale of new small off-road engines used in equipment which includes generators, lawn equipment, and other small off-road engine equipment.
- Seventeen states have adopted California's emissions standards over the past 20 plus years and nine states have recently passed laws and/or resolutions rejecting government deciding what technology American consumers must purchase. Virginia is the first state to untangle itself from California's emissions standards and EV mandates while Connecticut, Maine, New Jersey, Ohio, Louisiana, Georgia, Kentucky & Kansas were also submitting legislation to prevent the California 2035 100% zero emissions strategy from being adopted or allowing vehicle choice by states and not by government mandate.
- California legalized "cruising" in 2023 and other states which had previously followed California's lead that allowed communities to ban or restrict "cruising", were also attempting to undo the ban.
- Maine was attempting to increase from 25 years to 35 years the definition of an antique vehicle.

So, as the EV evolution and zero emissions strategies nationally continue overshadow our collector cars as well as our daily drivers and lawn mowers, we have to carefully monitor our own state's General Court.

MASS MOTOR VAULT
@ Rte 24 & 495
"Car storage for your favorite ride"
massmotorvault@gmail.com
617-320-2525
massmotorvault.com @mass.motor.vault

AUTOMOBILE APPRAISALS
Antiques*Classics*Street Rods*Pre-Purchase

DAN KENNEDY
MA License #8858

(781)936-8112
(781)733-5606 cell
Kingston, MA

AH Car Storage
Almost Heaven for Your Pride & Joy
in Holliston, MA

Ron Pfeifer, Owner 508-498-1608
www.ahcarstorage.com



Support Our Advertisers

BigWheel

508-763-5927

**TOWING • RECOVERY • HAZMAT
TRUCK SALES • DIESEL REPAIR**

Peluso Precision Automotive

Service Maintenance

Vintage and Contemporary Motorscars

93 Blackstone St. (508) 478-8900 Mendon, MA 01756

Thonus North

Plumbing • Heating
Air Conditioning

Inc. 508-430-1150

Service • Maintenance • Installations

License No. 33651 Harwich, MA
Michael R. Grillo PRESIDENT
Michael.Grillo@thonusnorth.com

menchie's frozen yogurt

menchie's patriot place
268 Patriot Place
Foxborough, MA 02035
www.menchie.com (508) 543-8000

SOUTH SHORE BEARING

We're more than just bearing distributors

111 Copeland Street
Quincy, Massachusetts 02169
(617) 471-7800

We are antique and performance vehicle specialists since 1959

www.southshorebearing.com Stephen W. Dymont

your personal service insurance agency

REINBOLD

INSURANCE AGENCY, INC.

860 LANDRY AVENUE
NO. ATTLEBORO, MASSACHUSETTS 02760

DOUG REINBOLD OFFICE:
doug@reinboldinsurance.com 508-695-0314 & 508-695-0554
www.reinboldinsurance.com FAX: 508-699-2583

Orphan Car GARAGE

John C Wingle
508-954-8090
www.OrphanCarGarage.com

Sales - Service - Parts - Plows - Sanders

LVJ TRAILERS

Dave, Bonnie and Kyle Lovejoy
Lvjequipment@comcast.net 77 Pond Street
www.lvjtrailers.com Norfolk, MA 02056
1-508-384-2808

SEEKONK Speedway

SINCE 1944

The Action Track Rocks with Fun & Excitement
Every Friday & Saturday Night
May Thru October!

SeekonkSpeedway.com

SCAN ME

LARRY NYBORN

Buyers • Recyclers • Assayers

Gold-Silver-Platinum-Palladium-Diamonds

Fast Accurate Evaluation and Payment

253B REVERE ST. CANTON, MA 02021
(781)828-3442 PMRSnorth@yahoo.com

ONE STOP PAINTING & RENOVATING

Call 508-888-3500
https://www.onestoppainting

ENGINEERED COMPONENTS inc.

EST. 1980

www.ecihotrodbrakes.com 866-872-7046 HOTRODBRAKES@SBCGLOBAL.NET

Hot Rod Brakes & Brackets

Manufactured in Ellington, CT USA

Braking system components for:

- Chevrolet, passenger cars and pickups from 1928 to early 1970s
- Chrysler, Dodge, Desoto, Plymouth: 1937 - 1972
- Ford, passenger cars and pickups: 1937 - 1972
- Corvette: 1953 - 1962
- Mustang II disc brake systems
- GM Muscle Car and Tri-Five Chevy zero-wheel offset disc brake conversions
- Narrow Trak disc brake systems for GM Muscle Cars and sub framed vehicles which move your wheels in 1" per side!
- Bolt in and universal pedal assemblies, brake valving and much more!

Phone: 617-522-4444

MORRISON'S AUTO-RITE INC.

COMPUTERIZED TUNE-UPS
BRAKE, STRUT & EXHAUST SERVICE

MORRISONSAUTORITE.COM

475 Centre Street Jamaica Plain, MA 02130-2020

329 Depot St. (Rte. 123) S. Easton, MA 02375

Open/enclosed Deckovers
ATV • Utility • Motorcycles
Landscape • Car Haulers
Snowmobiles
Dump • Equipment

1-800-SP1-IRON (508) 230-0032
771-4766 FAX (508) 230-7815

PROUD TO BE FOXBORO'S AUTO PARTS SPECIALIST

132 Washington St. (U.S. Rte. 1) Next to State Police

508-543-2210

Quality Parts and Service You Can Count On

OPEN 6 DAYS

Two More Locations

415 Washington St. 863 Plain St.
Quincy, MA 617-479-4343 781-834-1972
781-834-1972

Order Online at www.NAPAOnline.com

THE Sixties DINER

BREAKFAST & LUNCH

1210 PROVIDENCE HWY.
NORWOOD, MA
(781) 313-1006

Zoom Classic Cars

Jeff - (617)800-6737
jeff.zoomccc@gmail.com

www.ZoomClassicCars.com

DentTech

Paintless Dent Removal

Eric Mardenly
401-573-8393

Free Estimates | By Appointment Only

859 Washington Street • Attleboro, MA 02703

BRIGGS

GARDEN AND HOME SINCE 1961

STEVE SHUMILA RETAIL MANAGER

{P}508.699.7421 {F}508.695.4721 {E}info@briggsgarden.com
295 Kelley Boulevard, North Attleboro, Massachusetts 02760
www.briggsgarden.com

www.needjobs.com Lou Valentine

NEED

Personnel Placement

New England Engineers & Designers Inc.

129 Morgan Drive Tel: 781-769-4390
Suite 201 Fax: 781-769-1245
Norwood, MA 02062 lou@needjobs.com

COLONIAL AUTO PARTS

13 WILKENS DRIVE
PLAINVILLE, MASS

508-695-7167

PETE MAGNUSON AL MAGNUSON

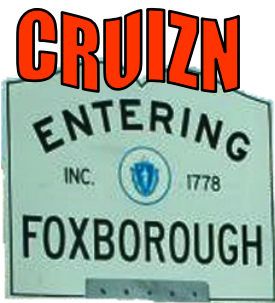

2024 AUGUST CRUIZN season

August is when all the known cruise venues are running HOT and HEAVY.
But, be sure to confirm these posted cruise venues dates before hitting the road to be sure.
Email your CRUIZN updates to usjbh@comcast.net

Still CRUIZN at the Speed of Fun



✓ **BOLD** are confirmed for 2024; **GREYED** cruises were from 2023

Monday:

- ✓ **Acushnet:** Legendary Street Rods @ Tuttle VFW, 28 Roosevelt St., 4–7 pm
- ✓ **Bellingham:** Bellingham VFW 7272; 940 S. Main St. (Rte. 126) 4-9 PM
- ✓ **Bridgewater:** PCMC Cruise @ Mass Motor Vault; 1221 Bedford St. 3-7 PM
- ✓ **Burlington:** ; 240 Middlesex Tpke & Rte.62, 5 PM
- ✓ **Phillipston:** N. Quabbin Cruisers @ Red Hill Farm, 455 Highland Ave. 4:30
- ✓ **Whitman:** SSSC Whitman VFW, 95 Essex St. 3:30 PM—Dusk
- ✓ **Bristol, RI:** Bristol VFW Cruise, 850 Hope St.; 4 PM weather permitting
- ✓ **Chepachet, RI:** Higher Std, bi-wkly, @ Hill's Tavern, 417 Putnam Pike; 6-9
- ✓ **Coventry, RI:** DAI Restore monthly cruise, 15 Ctr of New Eng., Blvd; 5 pm

Tuesday:

- ✓ **Auburn:** Tuttle Post 279 American Legion, 88 Bancroft St.; 4-7 PM
- ✓ **Billerica:** Road Rebels Cruise at Billerica Elks Pavilion; 14 Webb Rd. 5–8 PM
- ✓ **Bourne:** Upper Cape Cod Tech School Cruise; 220 Sandwich Rd. 5–7:30 PM
8/13, 8/27
- ✓ **Devens:** Clear Path for Vets Cars & Coffee, 84 Antietam St., 8:30–9:30 AM
- ✓ **Sandwich:** Sham Rods @ Sandwich H.S., 365 Quaker Mtg. Rd. 5 PM
- ✓ **Sharon:** Canton Rite Aide Cruise @ Sharon Heights Plaza, 366 S. Main St; 5–8
- ✓ **Upton:** Cruisin' at the V.F.W, Post 5594, 15 Milford St. (Rte. 140); 5-8 PM
- ✓ **Walpole:** E.C.C.C. Static Cruise at DD, 995 Old Post Rd. (off Rte. 1), 4-6 PM
- ✓ **Westport:** Bristol County C. C. @ White's, 66 State Rd. 1st Tues. of mo. 4 PM
- ✓ **Greenville/Smithfield, RI:** A&W Rte.44 (I-295 Exit 7); 4-9PM (Bruce P.)
- ✓ **N. Smithfield, RI:** Beef Barn Restaurant, 200 Industrial Dr.. 4 PM
- ✓ **Pawtucket, RI:** Slater Park, Armistice Blvd. or Rte. 1A 5–Dusk
- ✓ **Warwick, RI:** Oakland Beach Cruise Night, Rte. 1A, 4-8pm \$2 entry
- ✓ **Westerly, RI:** Misquamicut Beach, 257 Atlantic Ave. 5-8 PM

Wednesday:

- ✓ **Abington:** SCCC Abington Ale House, 1235 Bradford St. (Rte. 18), 3:30
- ✓ **Chelmsford:** Drum Hill Burger King, Rte. 3 Exit 32, 5 PM til dusk
- ✓ **Danvers:** Cruising the Tree, **NEW** 5 pm
- ✓ **E. Freetown:** Downshifters @ VFW, 89 Middleboro Rd.; 4–8 PM
- ✓ **E. Taunton:** Star Drive-In, 205 Myricks St. (Rte. 79–Rte.140 x 16); 4–9 PM
- ✓ **Hanover:** Silver Lake C.C. @ Shaw's Market, 35 Columbia Rd. (Rte.53) 2PM
- ✓ **Hopedale:** Hopedale Pizza Market, 1 Menfi Way @ the airport; 5PM—dusk
- ✓ **N. Attleboro:** N.A. Elks, 52 Bulfinch St. 5 pm—Dusk: every other Wed.
8/14, 8/28, 9/11, 9/25, 10/9
- ✓ **N. Attleboro:** Sta. Nation, 1505 S. Washington 6-10 pm: every other Wed.
- ✓ **Taunton:** The Pines @ The Lafayette Club, 18 Lakeview Ave. , 4-8pm
- ✓ **Cranston, RI:** Marasco's Bar & Grill, 985 Park Ave. 4-8pm (Johnny Nardo)
- ✓ **N. Scituate, RI:** Fredrickson Farms, 1458 Chopmist Rd.(Rte 102) (Bruce P.)
- ✓ **Lincoln, RI:** East Coast Finest Unicorn Ink, 100 Higginson Ave., 6-9pm

Thursday:

- ✓ **Brockton:** W.O.T. Cruise at Brewster Ambulance, 1555 Main St.; 4-Dusk
8/1, 8/15, 8/29, 9/28, 10/12
- ✓ **Foxboro:** Bass Pro Shops, 1 Bass Pro Pl. (U.S. Rte. 1) (Bruce P) 4:30 PM
8/22, 9/5, 9/19, 10/3, 10/17
- ✓ **North Reading:** Kitty's Restaurant, 123 Main St.(Rte. 28);4 pm -Dark
- ✓ **Shrewsbury:** Hebert Candy Mansion, 575 Hartford Pike/Rte. 20 5 PM
- ✓ **Stow:** Minuteman Air Field Wings & Wheels, 302 Foxboro Rd. 5-7 PM
- ✓ **Sturbridge:** Cruise Burger King, 374 Main St. (US Rte. 20) 4 PM
- ✓ **Portsmouth, RI:** Flo's Clamcakes & Cars, 324 Park Ave. Island Park; 4-8 pm

Friday:

- ✓ **Berkley:** American Legion All Wheels Cruise Night, 80 Myricks St. 4–10 PM
- ✓ **Brimfield:** Pioneer Valley Cruise Night, Auction Acres, 35 Main St. 4–8 PM
- ✓ **East Weymouth:** Food Truck Friday, 75 Middle St. (Town Hall) 5-8 PM
- ✓ **Gardner:** Polish/Amer. Club, 171 Kendall Pond Rd. (off Rte. 2A), 5–11 PM
- ✓ **Hallfax:** Walmart, 295 Plymouth St. (Rte. 106 at Rte. 58), 5–Dark
- ✓ **Lancaster:** Kimball Farm, 1543 Lunenburg Rd. (Rte. 70) 5-9 PM
- ✓ **Mattapoiset:** Shipyard Park, 12 Water St., 1st & 3rd Fri., 5–9 PM
8/2, 8/18, 9/6, 9/20
- ✓ **Rowley:** Todd Farm Auto Swap Meet & Car Show, 275 Main St.: 4th Fri. 3 PM
- ✓ **Westport:** VFW Cruise; 843 State Rd. (U.S. Rte.6) Last Fri. Monthly 5 PM
- ✓ **Cumberland, RI:** MacDonald's; 100 Mendon Rd. Rte. 122, 6 PM (Bruce P.)

Saturday:

- ✓ **Brookline:** Larz Anderson Cars & Coffee, 15 Newton St, 8:30–11:30 AM
8/17, 9/7, 10/5
- ✓ **Burlington:** Schoolhouse Ice Cream, 216 Cambridge St. (Rte. 3A) 5-8 PM
- ✓ **Millis:** Clicquot Cruise (Gold's Gym), 27 Milliston Rd. (Rte.109); 5 PM
- ✓ **Newburyport:** Cars & Coffee, McD's Port Plaza, 45 Story Ave.(Rte.113);7-9 AM
- ✓ **S. Dennis:** Patriot Square, upper Lot, Rte. 6—Exit 9 (Rte. 134) 4:30 — Dusk
- ✓ **Tyngsboro:** Dream Diner Car Show, 385 Middlesex Rd. 8 AM –1 PM
8/3, 8/10, 8/24, 9/21, 9/28
- ✓ **Riverside RI:** Crescent Park Carousel, 700 Bullocks Point Ave, 4-8 pm
- ✓ **Smithfield RI:** Classic Auto Cars & Coffee, 278 Douglas Pike; 8-11 am 3rd Sat

Sunday:

- ✓ **Attleboro:** Pleasant AutoCenter Cruise, 676 Pleasant St.(Rte. 123) 2-5PM
8/4, 8/18, 9/1, 9/15, 10/6, 10/27
- ✓ **Devens:** Clear Path for Veterans Cars & Coffee, 84 Antietam St..3rd Sun. 8 AM
- ✓ **Falmouth:** F.C.C.C. Monthly Cruise, Marine Park, Scranton Ave.;9 AM–2 PM
8/11 (no rain dates—Karen 508-364-0045)
- ✓ **Plainville:** An Unlikely Story Cars & Coffee, 111 South St. 8:30-10:30 AM
8/25, 9/29, 10/27 (last Sunday monthly)
- ✓ **Taunton:** The Pines @ The Lafayette Club, 18 Lakeview Ave.:3-7PM
- ✓ **Weymouth:** Cars & Coffee, Shaw's Plaza, 610 Middle St. 8–10 AM
- ✓ **Wilmington:** Kars N Koffee, As Good As It Gets, 25 Lowell St. 9am– 12
- ✓ **Newport RI:** Audrain Museum Car & Coffee 8–10 AM register your car online
8/4 (Park Place—Portsmouth); 8/11, 9/8, 9/22, 9/29, 10/13, 10/27 (Fort Adams);
8/18 (Newport Mansions TBD); 8/25, 9/15 (Newport Polo); 10/5 (Easton's 1st Beach)
10/20, 11/3, 11/10 (Sachuest 2nd Beach);
- ✓ **Warren, RI:** Laurens Restaurant; 601 Metacom Ave.; 4 PM—Dusk bi-weekly
8/11, 8/25 (Toys for Tots), 9/8, 9/22

For more cruise listings, check out these websites:

<https://massautoclubs.org/maynard-area-event-listing>
[amsvs news and events](https://amsvs.newsandevents.com)
[Home | CruisinBruce.com](https://Home.CruisinBruce.com)
<https://www.newenglandautoshow.com/>



CAR SHOWS, SWAP MEETS & EVENTS

By John Buchanan

AUGUST and a bit BEYOND 2024 Car Shows & Events Page

Events of interest that MASS CRUISERS Club members regularly support and attend are **asterisked ***

We use <https://massautoclubs.org/maynard-area-event-listing> to build a localized list; use it for more listings beyond this are

NOTE: This list of shows & events is our best effort to keep you informed; check with event organizers to be sure they are still ON.

- AUG 1-4,,,LOUISVILLE KY,,,NSRA STREET ROD NATIONALS,,,KY EXPO CENTER,,,,,,<http://www.nsra-usa.com>,,901 452-4030**
AUG 2-3,,,STURBRIDGE,,,RETURN TO MILLTOWN,,,HAMILTON ROD & GUN CLB-HAMILTON RD,,,1ST FRI/SAT,,,LANC,,413 283-6170
AUG 2-4,,,CHARLESTOWN RI,,,RISRA HOT RODS/HARLEYS HAUL,,,NINIGRET PARK,,4900 OLD POST RD 10-4PM,,,,,401-364-7323
AUG 3,,,SAT ,SWANSEA,,,NE SHELBY OWNERS 4TH ANNUAL CAR SHOW,,,SIMCOCK FARMS 293 MARVEL ST,,9-2PM,,,,,,RAIN DATE AUG. 4
AUG 3,,,WHITMAN,,,LUGNUTS ROUNDUP CAR SHOW AT VFW 95 ESSEX..8-1pm,,,200 CAR LIMIT,,,,,,HAL,,617-851-0975
AUG 4,,,BROCKTON,,,ALL BUICK ONLY CAR SHO/MINUTEMAN CHAPTER,,BREWSTER AMBULANCE SITE 10-2,,jgriffin_iii@hotmail.com
AUG 4,,,BROOKLINE,,,TUTTO ITALIAN CAR DAY,,MUSEUM OF TRANSPORTATION,,15 NEWTON ST,,larzanderson.org,,617 522-6547
AUG 4,,,HATFIELD,,,43RD CHEVY/GMC CAR/TRUCK ALL MAKES SHOW LIONS CLUB 15 BILLINGS WAY,,8-2,,BRYANT,,413 320-3215
AUG 4,,,STOUGHTON,,,CARS N COFFEE TO BENEFIT STOUGHTON YOUTH BASEBALL VFW FIELD 100 ELM ST,,8-NOON
AUG 4,,,WALTHAM,,,MOTORHEADSCARCLUB.NET CLASSIC CAR SHOW,,GORE PLACE 52 GORE ST,7-2:30PM,,DAVID,,508 633-2525
FIERO'S AT GORE PLACE,7AM,,BRING EM ON,,ALL THOSE THAT DIDN'T CATCH ON FIRE
PRE – WORLD WAR 2 and METZ CAR SHOW/METZ REUNION GREGG , , 508 320-8876
STEAM CARS WILL BE PRESENT AT THIS SHOW,,SOUNDS LIKE A GREAT EVENT AT GORE PLACE,,508 320-8876
WOODY WAGONS AT GORE PLACE,,52 GORE ST,,POSTPONED TILL 2025,,CALL 508 320-8876
- AUG 4,,,LINCOLN RI,,,MCCNE MUSTANG CAR SHOW,,BALLY'S 100 TWIN RIVER RD,,,,,cruisinbruce.com,,BRUCE,,401 862-2719**
AUG 10,,,AUBURN,,,HIGH OCTANE CLASSICS CARS AND COFFEE 9-1,,141 WASHINGTON ST,,508 859-4515,,GREGG,,508 320-8876
AUG 10-11,,,BOYLSTON,,,STRAW HOLLOW ENGINE SHOW,,PAUL TIVNAN DR,,2- full wkend,,DAN,,508-869-2722
AUG 10,,,LEOMINSTER,,,RATTLERS HOT ROD REUNION,,EAGLES CLUB 458 LITCHFIELD ST,,10-4,,72/OLDER,,,,,603 381-8658
AUG 10,,,PEPPERELL,,,AI ALL WHEELS CAR SHOW,,,THAT'S ALL I HAVE,,,,,,cruisinbruce.com,,BRUCE,,401 862-2719
AUG 10,,,UXBRIDGE,,,1ST EVER JEEP SHOW,,320 SUTTON ST,,12NOON,,
AUG 11,,,FALMOUTH,,,FALM CLASSIC CC MARINE PARK/SCRANTON AVE,,9-2,,falmouthclassiccarrclub.com,,KAREN,,508-364-0045
AUG 11,,,TOWNSEND,,,GAVIN BYERS ART-TATTOO OPEN HOUSE/FREE CAR/BIKE SHOW,,9 GILCHRIST RD 10-4PM,,978 790-1982
AUG 11,,,WESTFIELD,,,CLASSIC AUTO SHOW MESTEK INC 260 N ELM ST,,10-3PM,,FACEBOOK OR,,westfieldcruisers.com
AUG 11,,,WHITMAN,,,BENJAMIN DUFOR CLASSICS FOR A CAUSE,,VFW,,95 ESSEX ST,,12-5PM
AUG 11,,,BRISTOL RI,,,D REILLY CRUISIN FOR A CAUSE CAR SHOW 250 METACOM AVE,,8-3,,,,,,RICH,,401 575-6933
***AUG 11,,,CUMBERLAND RI,,,RI CHEVY OWNERS CAR SHOW,,,STOP 7 SHOP PLAZA,,70 MENDON RD,,9-2 PM,,781-7600433**
AUG 11,,,NARRAGANSETT RI,,,CORVETTES BY/SEA,,OCEAN TIDES SCHOOL,,635 OCEAN RD 11-3,,corvetteclubofrhodeisland.com
AUG 11,,,PUTNAM CT,,,DOWNTOWN MAIN STREET CAR CRUISE,CTs BIGGEST,,,10-3PM,,2 MUCH 2 LIST,,JUST COME
AUG 17,,,ANDOVER,,,AACA BEAN POT'S SUMMER SHOW AT MELMARK 461 RIVER RD,,9-1PM,,beanpotaaca.org,,DAN,,781 248-7410
AUG 17,,,BOYLSTON,,,BRING THE HEAT CARS SHOW,,BOTANIC GARDENS 11 FRENCH DR,,8-2PM
AUG 17,,,FALL RIVER,,,FAT CAT RALPHS WHEELS/MEALS/DEALS,,VFW 486 BEDFORD ST,,10-3PM,,RALPH,,774 294-4595
AUG 17,,,NORTON,,,HOT RODS 4 HORSES CAR SHOW,,SMOKEY CHESTNUT FARM 98A BURT ST,,11-4pm,,smokeychestnotfarm.com
AUG 17,,,SOUTH DENNIS,,,capecodclassics.org BLAST FROM THE PAST BENEFIT CAR SHOW,,PATRIOTS SQ,,11-4,,RON,,508 619-7995
AUG 17,,,WALTHAM,,,ANNUAL MOODY STREET CAR SHOW,,12-4:30,,ENTIRE ST WILL BE SHUT DOWN,,,,,CHARLIE,,617 257-2315
AUG 17,,,WHITINSVILLE,,,CARS IN THE PARK CAR SHOW,,WHITINSVILLE PARK,,60 MAIN ST,,10-4PM,,,,,,508 234-8184
AUG 17,,,MIDDLETOWN RI,,,BLENHEIM ASSISTED LIVING,,303 VALLEY RD,,SEE CRUISIN BRUCE WEBSITE FOR DETAILS,,401 239-2509
AUG 17,,,WARWICK RI,,,RI SHRINERS WORLD OF WHEELS,,MASONIC YOUTH CTR 116 LONG ST,,9AM-3,,401 952-5892
AUG 18,,,BERKLEY,,,BERKLEY FIRE ASSOC CAR SHOW ON THE COMMON 5 N MAIN ST,,9-3PM,,,,,,RYAN,,508 567-5299
AUG 18,,,BROOKLINE,,,SWEDISH CAR DAY,,MUSEUM OF TRANSPORTATION,,15 NEWTON ST,,larzanderson.org,,617 522-6547
AUG 18,,,GLOUCESTER,,,WATERFRONT FESTIVAL,,CAR SHOW SUNDAY 9AM,,STAGE FORT PK,,,nsocc,TERRY,,603 332-2616
***AUG 18,,,SHARON,,,ANNUAL B&D AUTOMOTIVE CAR SHOW,,CRESCENT RIDGE DAIRY 407 BAY RD,,9AM-2PM,,781-341-3000**
AUG 18,,,SHREWSBURY,,,STAY DRIVEN CHARITY CAR SHOW 14 FORTUNE BLVD,,9AM,,TILL?
AUG 18,,,PORTSMOUTH RI,,,R & S ROD RUN,,SPEED SHOP 3123 E MAIN ST,,72 AND OLDER VEHICLES,,10AM-TILL?
AUG 18,,,PROVIDENCE RI,,,MONROE DAIRY CRUISE TO THE COW,,187 N. BROW ST. E,,FREE ADMIT & CONE TO EA. CAR,, 3 PM AWARDS @ 5
AUG 23-24,,,WESTFORD,,,18TH CHEVELLE/EL-CAMINO REGIONL SHO/WESTFORD REGENCY,,chev-el.com,,KEN,,774-275-0304
***AUG 24,,,MIDDLEBORO,,,GATHERING/FAITHFUL,,22ND N ENGLAND SPEED MTG PIERCE PLAYBGRND 26 JACKSON ST 9AM-3PM,,508-888-3103**
AUG 24,,,PLYMOUTH,,,WATERFRONT FESTIVAL CAR SHOW,,WATER ST,,,plymouthwaterfrontfestival.com,,508 830-1620
AUG 24,,,SAUGUS,,,CARS/COPS SHOW,,BLESSSED SACRAMENT CATHOLIC CHURCH 14 SUMMER ST,,9-2,,carsandcopscarshow.com,,
AUG 24,,,SUDBURY,,,JAGUAR CLUB NORTH AMERICA CONCOURS d' ELEGANCE,,WAYSIDE INN RT20,,8AM,,BOB ,,603 772-1116
AUG 24,,,WESTFORD,,,NETSCOUT ALL WHEELS CANCER FUNDRAISER SHOW,,310 LITTLETON RD 10-2PM,,
AUG 25,,,BROOKLINE,,,BMW DAY,,,,,,MUSEUM OF TRANSPORTATION,,15 NEWTON ST,,larzanderson.org,,617 522-6547
AUG 25,,,WALTHAM,,,ANNUAL LIONS CLUB AUTO SHOW,,RESERVOIR PLACE 1601 TRAPELO RD,,9-2PM,,,,,CHARLIE,,617 257-2315
AUG 25,,,WEST GREENWICH RI,,,WHEELS FOR WISHES MISHNOCK BARN SHOW 10-3,,,cruisinbruce.com,,BRUCE,,401 862-2719
AUG 31,,,SHREWSBURY,,,MILLBURY LIONS CARS SHOW,,HEBERT CANDY MANSION 574 HARTFORD TPKE 10-2PM,,508-335-3666
***AUG 31,,,CUMBERLAND RI,,,CREEPS CC HOT RODS ON THE HILL PRE 70 CAR SHOW,,DIAMOND HILL PK,,11-5,,MARK,,401-529-6243**
***SEP 1,,,MARSHFIELD,,,SPINDLES3 CC CAR SHOW & SWAP MEET,,,,,MARSHFIELD FAIRGROUNDS,RTS 139/3A,,JEN,,781 335-9754**
***SEP 2,,,ATTLEBORO,,,BRISTOL COUNTY STREET ROD 44TH LABOR DAY LAY BACK,,ELKS-RT 152,,,,,WOODY,,508 222-7518**
***SEP 5-8,,,LAKE GEORGE NY,,,33RD ANN ADIRONDACK NATIONALS,,FT WM HENRY,,,,,adirondacknationals.com,,207 443-9065**
SEP 7,,,SHREWSBURY,,,MILLBURY LIONS CARS SHOW,,HEBERT CANDY MANSION 574 HARTFORD TPKE 10-2PM,,BRUCE,,401 862-2719
SEP 7,,,WORCESTER,,,IMPORT EVOLUTION CAR SHOW AT THE DCU CENTER 50 FOSTER ST,,1PM,,
SEP 7,,,UXBRIDGE,,,1ST ANNUAL ST MARY'S BENEFIT CAR SHOW,,UHS ON 300 QUAKER WAY,,8-2,,JEFF,,508 475-8950
SEP 7,,,PORTSMOUTH RI,,,ATRIA AQUIDNECK FAMILY CRUISE DAY,,,,,,cruisinbruce.com,,BRUCE,,401 862-2719
***SEP 8,,,LANCASTER,,,50TH TY-ROD OLD TIMERS REUNION,,RT 117-9AM,,BOLTON FAIRGROUNDS,,ty-rods.org,,978-357-3801**